

## Chapter 5 Link Layer

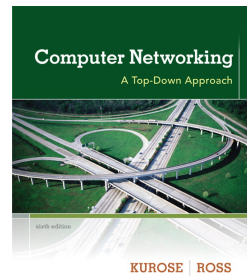

A note on the use of these ppt slides:

We're making these slides freely available to all (faculty, students, readers). They're in PowerPoint form so you see the animations; and can add, modify, and delete slides (including this one) and slide content to suit your needs. They obviously represent a lot of work on our part. In return for use, we only ask the following:

- ❖ If you use these slides (e.g., in a class) that you mention their source (after all, we'd like people to use our book!)
- ❖ If you post any slides on a www site, that you note that they are adapted from (or perhaps identical to) our slides, and note our copyright of this material.

Thanks and enjoy! JFK/KWR

©All material copyright 1996-2012  
J.F Kurose and K.W. Ross, All Rights Reserved

**Computer  
Networking: A Top  
Down Approach**  
6<sup>th</sup> edition  
Jim Kurose, Keith Ross  
Addison-Wesley  
March 2012

Link Layer 5-1

## Chapter 5: Link layer

*our goals:*

- ❖ understand principles behind link layer services:
  - error detection, correction
  - sharing a broadcast channel: multiple access
  - link layer addressing
  - local area networks: Ethernet, VLANs
- ❖ instantiation, implementation of various link layer technologies

Link Layer 5-2

## Link layer, LANs: outline

- 5.1 introduction, services
- 5.2 error detection, correction
- 5.3 multiple access protocols
- 5.4 LANs
  - addressing, ARP
  - Ethernet
  - switches
  - VLANs
- 5.5 link virtualization: MPLS
- 5.6 data center networking
- 5.7 a day in the life of a web request

Link Layer 5-3

## Link layer: introduction

### *terminology:*

- ❖ hosts and routers: **nodes**
- ❖ communication channels that connect adjacent nodes along communication path: **links**
  - wired links
  - wireless links
  - LANs
- ❖ layer-2 packet: **frame**, encapsulates datagram

*data-link layer* has responsibility of transferring datagram from one node to *physically adjacent* node over a link

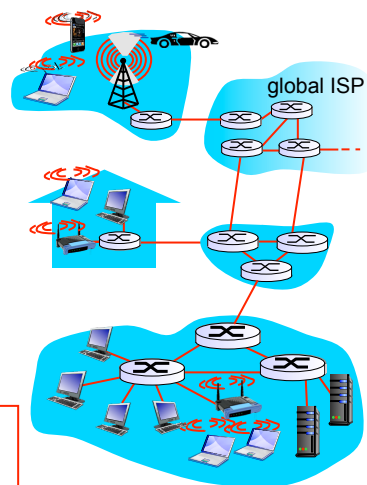

Link Layer 5-4

## Link layer: context

- ❖ datagram transferred by different link protocols over different links:
    - e.g., Ethernet on first link, frame relay on intermediate links, 802.11 on last link
  - ❖ each link protocol provides different services
    - e.g., may or may not provide rdt over link
- transportation analogy:*
- ❖ trip from Princeton to Lausanne
    - limo: Princeton to JFK
    - plane: JFK to Geneva
    - train: Geneva to Lausanne
  - ❖ tourist = **datagram**
  - ❖ transport segment = **communication link**
  - ❖ transportation mode = **link layer protocol**
  - ❖ travel agent = **routing algorithm**

Link Layer 5-5

## Link layer services

- ❖ *framing, link access:*
  - encapsulate datagram into frame, adding header, trailer
  - channel access if shared medium
  - “MAC” addresses used in frame headers to identify source, dest
    - different from IP address!
- ❖ *reliable delivery between adjacent nodes*
  - we learned how to do this already (chapter 3)!
  - seldom used on low bit-error link (fiber, some twisted pair)
  - wireless links: high error rates
    - Q: why both link-level and end-end reliability?

Link Layer 5-6

## Link layer services (more)

- ❖ **flow control:**
  - pacing between adjacent sending and receiving nodes
- ❖ **error detection:**
  - errors caused by signal attenuation, noise.
  - receiver detects presence of errors:
    - signals sender for retransmission or drops frame
- ❖ **error correction:**
  - receiver identifies *and corrects* bit error(s) without resorting to retransmission
- ❖ **half-duplex and full-duplex**
  - with half duplex, nodes at both ends of link can transmit, but not at same time

Link Layer 5-7

## Where is the link layer implemented?

- ❖ in each and every host
- ❖ link layer implemented in “adaptor” (aka *network interface card* NIC) or on a chip
  - Ethernet card, 802.11 card; Ethernet chipset
  - implements link, physical layer
- ❖ attaches into host’s system buses
- ❖ combination of hardware, software, firmware

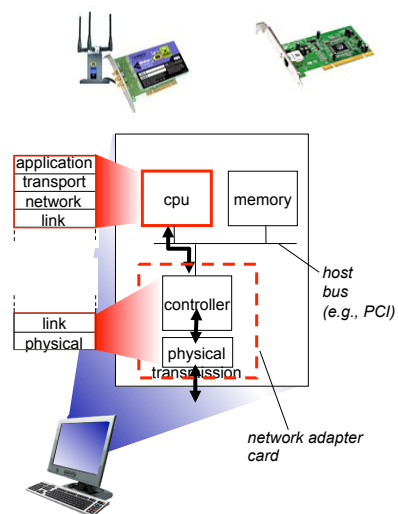

Link Layer 5-8

## Adaptors communicating

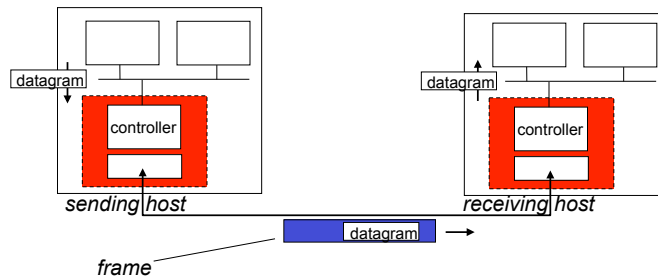

- ❖ sending side:
  - encapsulates datagram in frame
  - adds error checking bits, rdt, flow control, etc.
- ❖ receiving side
  - looks for errors, rdt, flow control, etc
  - extracts datagram, passes to upper layer at receiving side

Link Layer 5-9

## Link layer, LANs: outline

- 5.1 introduction, services
- 5.2 error detection, correction
- 5.3 multiple access protocols
- 5.4 LANs
  - addressing, ARP
  - Ethernet
  - switches
  - VLANS
- 5.5 link virtualization: MPLS
- 5.6 data center networking
- 5.7 a day in the life of a web request

Link Layer 5-10

# Error detection

EDC= Error Detection and Correction bits (redundancy)  
 D = Data protected by error checking, may include header fields

- Error detection not 100% reliable!
  - protocol may miss some errors, but rarely
  - larger EDC field yields better detection and correction

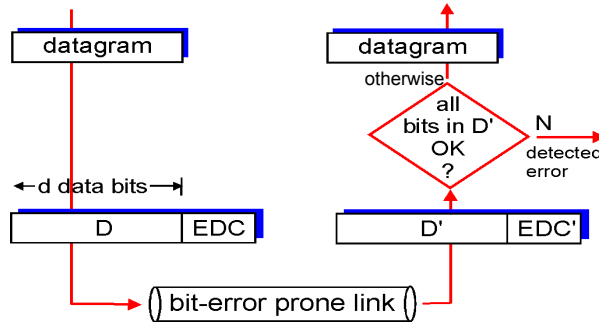

Link Layer 5-11

# Parity checking

## single bit parity:

- ❖ detect single bit errors

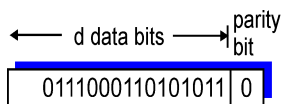

## two-dimensional bit parity:

- ❖ detect and correct single bit errors

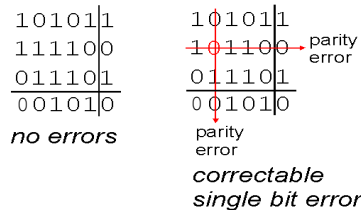
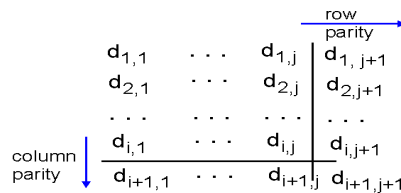

Link Layer 5-12

## Internet checksum (review)

*goal:* detect “errors” (e.g., flipped bits) in transmitted packet  
(note: used at transport layer *only*)

### *sender:*

- ❖ treat segment contents as sequence of 16-bit integers
- ❖ checksum: addition (1’s complement sum) of segment contents
- ❖ sender puts checksum value into UDP checksum field

### *receiver:*

- ❖ compute checksum of received segment
- ❖ check if computed checksum equals checksum field value:
  - NO - error detected
  - YES - no error detected.  
*But maybe errors nonetheless?*

Link Layer 5-13

## Cyclic redundancy check

- ❖ more powerful error-detection coding
- ❖ view data bits, **D**, as a binary number
- ❖ choose  $r+1$  bit pattern (generator), **G**
- ❖ goal: choose  $r$  CRC bits, **R**, such that
  - $\langle D, R \rangle$  exactly divisible by  $G$  (modulo 2)
  - receiver knows  $G$ , divides  $\langle D, R \rangle$  by  $G$ . If non-zero remainder: error detected!
  - can detect all burst errors less than  $r+1$  bits
- ❖ widely used in practice (Ethernet, 802.11 WiFi, ATM)

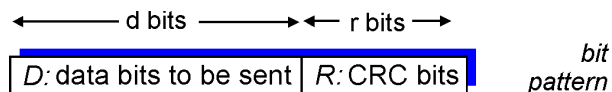

$$D * 2^r \text{ XOR } R \quad \text{mathematical formula}$$

Link Layer 5-14

## CRC example

want:

$$D \cdot 2^r \text{ XOR } R = nG$$

equivalently:

$$D \cdot 2^r = nG \text{ XOR } R$$

equivalently:

if we divide  $D \cdot 2^r$  by  $G$ , want remainder  $R$  to satisfy:

$$R = \text{remainder} \left[ \frac{D \cdot 2^r}{G} \right]$$

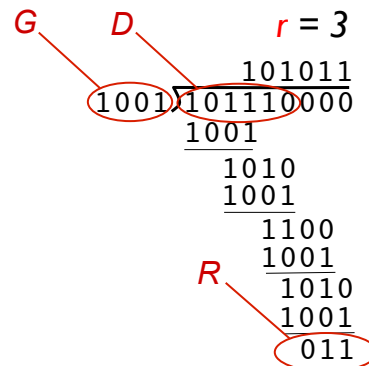

Link Layer 5-15

## Link layer, LANs: outline

5.1 introduction, services

5.2 error detection, correction

5.3 multiple access protocols

5.4 LANs

- addressing, ARP
- Ethernet
- switches
- VLANS

5.5 link virtualization: MPLS

5.6 data center networking

5.7 a day in the life of a web request

Link Layer 5-16

## Multiple access links, protocols

two types of “links”:

- ❖ point-to-point
  - PPP for dial-up access
  - point-to-point link between Ethernet switch, host
- ❖ *broadcast (shared wire or medium)*
  - old-fashioned Ethernet
  - upstream HFC
  - 802.11 wireless LAN



shared wire (e.g.,  
cabled Ethernet)



shared RF  
(e.g., 802.11 WiFi)



shared RF  
(satellite)



humans at a  
cocktail party  
(shared air, acoustical)

Link Layer 5-17

## Multiple access protocols

- ❖ single shared broadcast channel
- ❖ two or more simultaneous transmissions by nodes:  
interference
  - *collision* if node receives two or more signals at the same  
time

### *multiple access protocol*

- ❖ distributed algorithm that determines how nodes share  
channel, i.e., determine when node can transmit
- ❖ communication about channel sharing must use channel itself!
  - no out-of-band channel for coordination

Link Layer 5-18

## An ideal multiple access protocol

*given:* broadcast channel of rate  $R$  bps

*desiderata:*

1. when one node wants to transmit, it can send at rate  $R$ .
2. when  $M$  nodes want to transmit, each can send at average rate  $R/M$
3. fully decentralized:
  - no special node to coordinate transmissions
  - no synchronization of clocks, slots
4. simple

Link Layer 5-19

## MAC protocols: taxonomy

three broad classes:

- ❖ *channel partitioning*
  - divide channel into smaller “pieces” (time slots, frequency, code)
  - allocate piece to node for exclusive use
- ❖ *random access*
  - channel not divided, allow collisions
  - “recover” from collisions
- ❖ *“taking turns”*
  - nodes take turns, but nodes with more to send can take longer turns

Link Layer 5-20

## Channel partitioning MAC protocols: TDMA

### TDMA: time division multiple access

- ❖ access to channel in "rounds"
- ❖ each station gets fixed length slot (length = pkt trans time) in each round
- ❖ unused slots go idle
- ❖ example: 6-station LAN, 1,3,4 have pkt, slots 2,5,6 idle

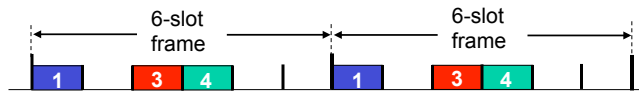

Link Layer 5-21

## Channel partitioning MAC protocols: FDMA

### FDMA: frequency division multiple access

- ❖ channel spectrum divided into frequency bands
- ❖ each station assigned fixed frequency band
- ❖ unused transmission time in frequency bands go idle
- ❖ example: 6-station LAN, 1,3,4 have pkt, frequency bands 2,5,6 idle

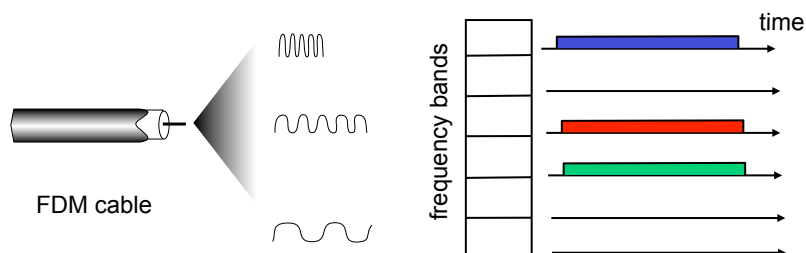

Link Layer 5-22

## Random access protocols

- ❖ when node has packet to send
  - transmit at full channel data rate  $R$ .
  - no *a priori* coordination among nodes
- ❖ two or more transmitting nodes → “collision”,
- ❖ **random access MAC protocol** specifies:
  - how to detect collisions
  - how to recover from collisions (e.g., via delayed retransmissions)
- ❖ examples of random access MAC protocols:
  - slotted ALOHA
  - ALOHA
  - CSMA, CSMA/CD, CSMA/CA

Link Layer 5-23

## Slotted ALOHA

### *assumptions:*

- ❖ all frames same size
- ❖ time divided into equal size slots (time to transmit 1 frame)
- ❖ nodes start to transmit only slot beginning
- ❖ nodes are synchronized
- ❖ if 2 or more nodes transmit in slot, all nodes detect collision

### *operation:*

- ❖ when node obtains fresh frame, transmits in next slot
  - *if no collision*: node can send new frame in next slot
  - *if collision*: node retransmits frame in each subsequent slot with prob.  $p$  until success

Link Layer 5-24

## Slotted ALOHA

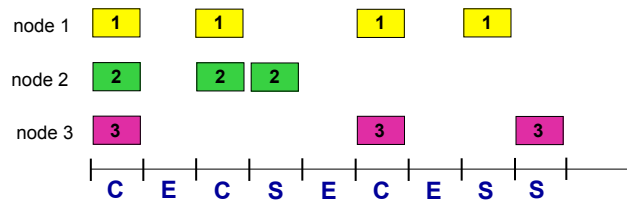

### Pros:

- ❖ single active node can continuously transmit at full rate of channel
- ❖ highly decentralized: only slots in nodes need to be in sync
- ❖ simple

### Cons:

- ❖ collisions, wasting slots
- ❖ idle slots
- ❖ nodes may be able to detect collision in less than time to transmit packet
- ❖ clock synchronization

Link Layer 5-25

## Slotted ALOHA: efficiency

**efficiency:** long-run fraction of successful slots (many nodes, all with many frames to send)

- ❖ suppose:  $N$  nodes with many frames to send, each transmits in slot with probability  $p$
- ❖ prob that given node has success in a slot =  $p(1-p)^{N-1}$
- ❖ prob that any node has a success =  $Np(1-p)^{N-1}$

- ❖ max efficiency: find  $p^*$  that maximizes  $Np(1-p)^{N-1}$
- ❖ for many nodes, take limit of  $Np^*(1-p^*)^{N-1}$  as  $N$  goes to infinity, gives:  
*max efficiency =  $1/e = .37$*

**at best:** channel used for useful transmissions 37% of time!



Link Layer 5-26

## Pure (unslotted) ALOHA

- ❖ unslotted Aloha: simpler, no synchronization
- ❖ when frame first arrives
  - transmit immediately
- ❖ collision probability increases:
  - frame sent at  $t_0$  collides with other frames sent in  $[t_0-1, t_0+1]$

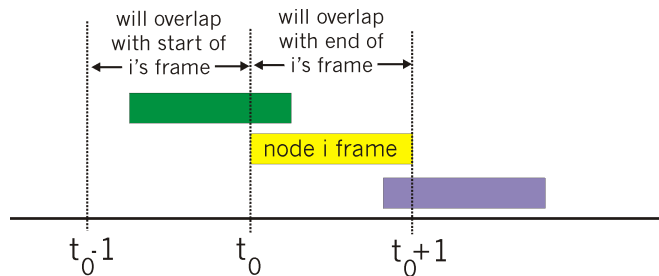

Link Layer 5-27

## Pure ALOHA efficiency

$$\begin{aligned} P(\text{success by given node}) &= P(\text{node transmits}) \cdot \\ & P(\text{no other node transmits in } [t_0-1, t_0]) \cdot \\ & P(\text{no other node transmits in } [t_0, t_0+1]) \\ &= p \cdot (1-p)^{N-1} \cdot (1-p)^{N-1} \\ &= p \cdot (1-p)^{2(N-1)} \end{aligned}$$

... choosing optimum  $p$  and then letting  $n \rightarrow \infty$

$$= 1/(2e) = .18$$

**even worse than slotted Aloha!**

Link Layer 5-28

## CSMA (carrier sense multiple access)

**CSMA:** listen before transmit:

if channel sensed idle: transmit entire frame

❖ if channel sensed busy, defer transmission

❖ human analogy: don't interrupt others!

Link Layer 5-29

## CSMA collisions

❖ collisions *can still occur*:  
propagation delay means  
two nodes may not hear  
each other's  
transmission

❖ collision: entire packet  
transmission time  
wasted

- distance & propagation  
delay play role in in  
determining collision  
probability

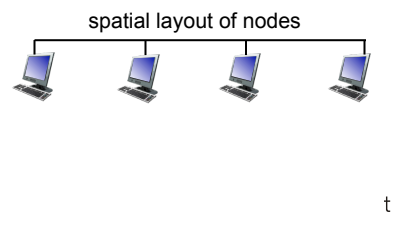

Link Layer 5-30

## CSMA/CD (collision detection)

**CSMA/CD:** carrier sensing, deferral as in CSMA

- collisions *detected* within short time
- colliding transmissions aborted, reducing channel wastage
- ❖ collision detection:
  - easy in wired LANs: measure signal strengths, compare transmitted, received signals
  - difficult in wireless LANs: received signal strength overwhelmed by local transmission strength
- ❖ human analogy: the polite conversationalist

Link Layer 5-31

## CSMA/CD (collision detection)

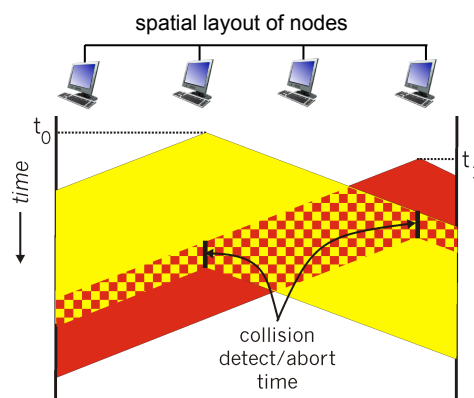

Link Layer 5-32

## Ethernet CSMA/CD algorithm

1. NIC receives datagram from network layer, creates frame
2. If NIC senses channel idle, starts frame transmission. If NIC senses channel busy, waits until channel idle, then transmits.
3. If NIC transmits entire frame without detecting another transmission, NIC is done with frame !
4. If NIC detects another transmission while transmitting, aborts and sends jam signal
5. After aborting, NIC enters *binary (exponential) backoff*:
  - after  $m$ th collision, NIC chooses  $K$  at random from  $\{0, 1, 2, \dots, 2^m - 1\}$ . NIC waits  $K \cdot 512$  bit times, returns to Step 2
  - longer backoff interval with more collisions

Link Layer 5-33

## CSMA/CD efficiency

- ❖  $T_{prop}$  = max prop delay between 2 nodes in LAN
- ❖  $t_{trans}$  = time to transmit max-size frame

$$efficiency = \frac{1}{1 + 5t_{prop}/t_{trans}}$$

- ❖ efficiency goes to 1
  - as  $t_{prop}$  goes to 0
  - as  $t_{trans}$  goes to infinity
- ❖ better performance than ALOHA: and simple, cheap, decentralized!

Link Layer 5-34

## “Taking turns” MAC protocols

### channel partitioning MAC protocols:

- share channel *efficiently* and *fairly* at high load
- inefficient at low load: delay in channel access, 1/N bandwidth allocated even if only 1 active node!

### random access MAC protocols

- efficient at low load: single node can fully utilize channel
- high load: collision overhead

### “taking turns” protocols

look for best of both worlds!

Link Layer 5-35

## “Taking turns” MAC protocols

### *polling:*

- ❖ master node “invites” slave nodes to transmit in turn
- ❖ typically used with “dumb” slave devices
- ❖ concerns:
  - polling overhead
  - latency
  - single point of failure (master)

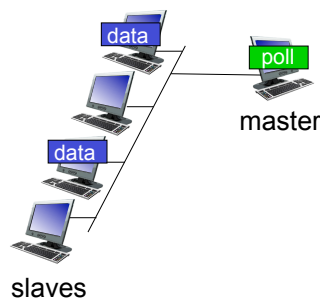

Link Layer 5-36

## “Taking turns” MAC protocols

### *token passing:*

- ❖ control *token* passed from one node to next sequentially.
- ❖ token message
- ❖ concerns:
  - token overhead
  - latency
  - single point of failure (token)

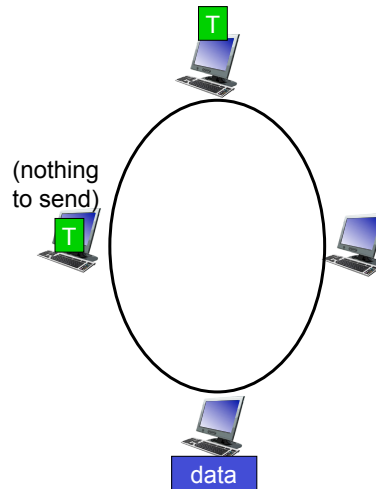

Link Layer 5-37

## Cable access network

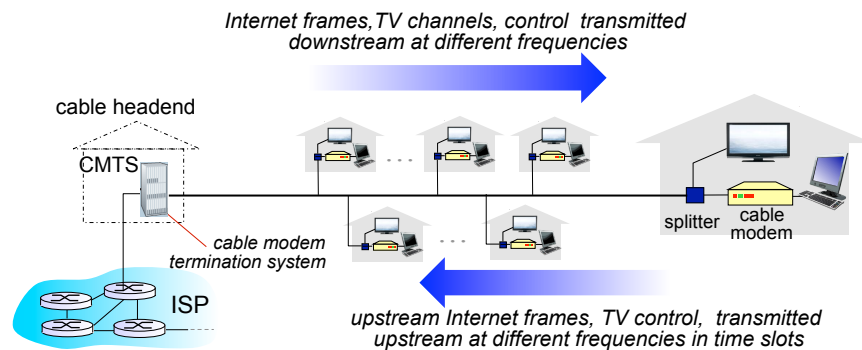

- ❖ **multiple** 40Mbps downstream (broadcast) channels
  - single CMTS transmits into channels
- ❖ **multiple** 30 Mbps upstream channels
  - **multiple access:** all users contend for certain upstream channel time slots (others assigned)

## Cable access network

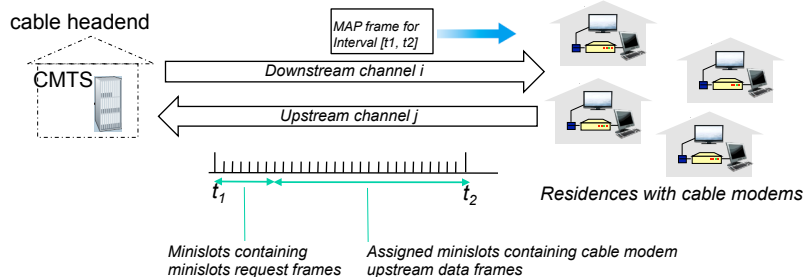

### **DOCSIS:** data over cable service interface spec

- ❖ FDM over upstream, downstream frequency channels
- ❖ TDM upstream: some slots assigned, some have contention
  - downstream MAP frame: assigns upstream slots
  - request for upstream slots (and data) transmitted random access (binary backoff) in selected slots

Link Layer 5-39

## Summary of MAC protocols

- ❖ *channel partitioning*, by time, frequency or code
  - Time Division, Frequency Division
- ❖ *random access* (dynamic),
  - ALOHA, S-ALOHA, CSMA, CSMA/CD
  - carrier sensing: easy in some technologies (wire), hard in others (wireless)
  - CSMA/CD used in Ethernet
  - CSMA/CA used in 802.11
- ❖ *taking turns*
  - polling from central site, token passing
  - bluetooth, FDDI, token ring

Link Layer 5-40

## Link layer, LANs: outline

- 5.1 introduction, services
- 5.2 error detection, correction
- 5.3 multiple access protocols
- 5.4 LANs
  - addressing, ARP
  - Ethernet
  - switches
  - VLANs
- 5.5 link virtualization: MPLS
- 5.6 data center networking
- 5.7 a day in the life of a web request

Link Layer 5-41

## MAC addresses and ARP

- ❖ 32-bit IP address:
  - *network-layer* address for interface
  - used for layer 3 (network layer) forwarding
- ❖ MAC (or LAN or physical or Ethernet) address:
  - function: *used "locally" to get frame from one interface to another physically-connected interface (same network, in IP-addressing sense)*
  - 48 bit MAC address (for most LANs) burned in NIC ROM, also sometimes software settable
  - e.g.: 1A-2F-BB-76-09-AD
    - hexadecimal (base 16) notation
    - (each "number" represents 4 bits)

Link Layer 5-42

## LAN addresses and ARP

each adapter on LAN has unique *LAN* address

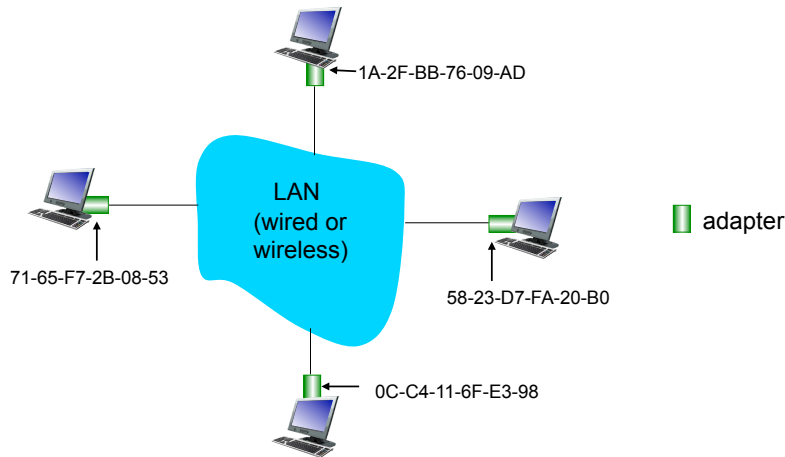

Link Layer 5-43

## LAN addresses (more)

- ❖ MAC address allocation administered by IEEE
- ❖ manufacturer buys portion of MAC address space (to assure uniqueness)
- ❖ analogy:
  - MAC address: like Social Security Number
  - IP address: like postal address
- ❖ MAC flat address → portability
  - can move LAN card from one LAN to another
- ❖ IP hierarchical address *not* portable
  - address depends on IP subnet to which node is attached

Link Layer 5-44

## ARP: address resolution protocol

**Question:** how to determine interface's MAC address, knowing its IP address?

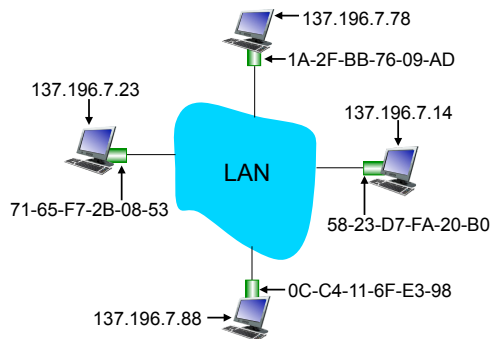

**ARP table:** each IP node (host, router) on LAN has table

- IP/MAC address mappings for some LAN nodes:  
< IP address; MAC address; TTL >
- TTL (Time To Live): time after which address mapping will be forgotten (typically 20 min)

Link Layer 5-45

## ARP protocol: same LAN

- ❖ A wants to send datagram to B
  - B's MAC address not in A's ARP table.
- ❖ A **broadcasts** ARP query packet, containing B's IP address
  - dest MAC address = FF-FF-FF-FF-FF-FF
  - all nodes on LAN receive ARP query
- ❖ B receives ARP packet, replies to A with its (B's) MAC address
  - frame sent to A's MAC address (unicast)
- ❖ A caches (saves) IP-to-MAC address pair in its ARP table until information becomes old (times out)
  - soft state: information that times out (goes away) unless refreshed
- ❖ ARP is "plug-and-play":
  - nodes create their ARP tables *without intervention from net administrator*

Link Layer 5-46

## Addressing: routing to another LAN

walkthrough: **send datagram from A to B via R**

- focus on addressing – at IP (datagram) and MAC layer (frame)
- assume A knows B's IP address
- assume A knows IP address of first hop router, R (how?)
- assume A knows R's MAC address (how?)

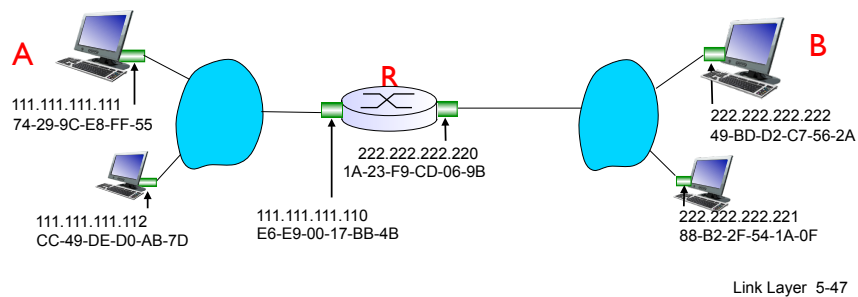

## Addressing: routing to another LAN

- ❖ A creates IP datagram with IP source A, destination B
- ❖ A creates link-layer frame with R's MAC address as dest, frame contains A-to-B IP datagram

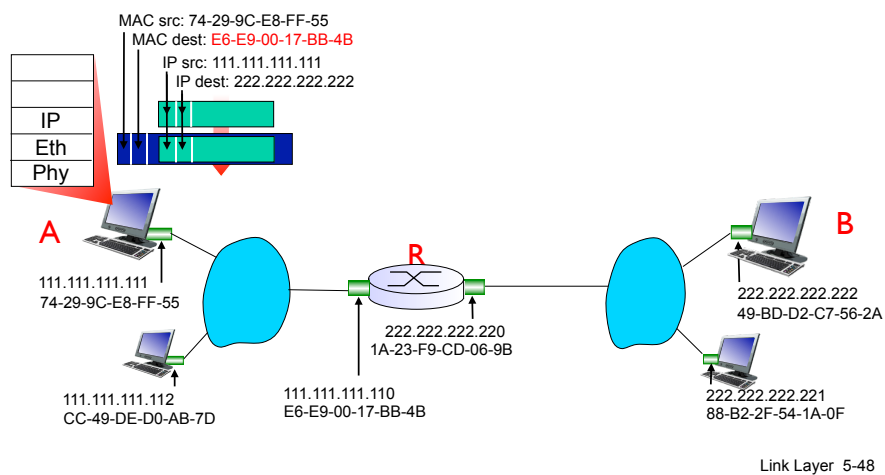

## Addressing: routing to another LAN

- ❖ frame sent from A to R
- ❖ frame received at R, datagram removed, passed up to IP

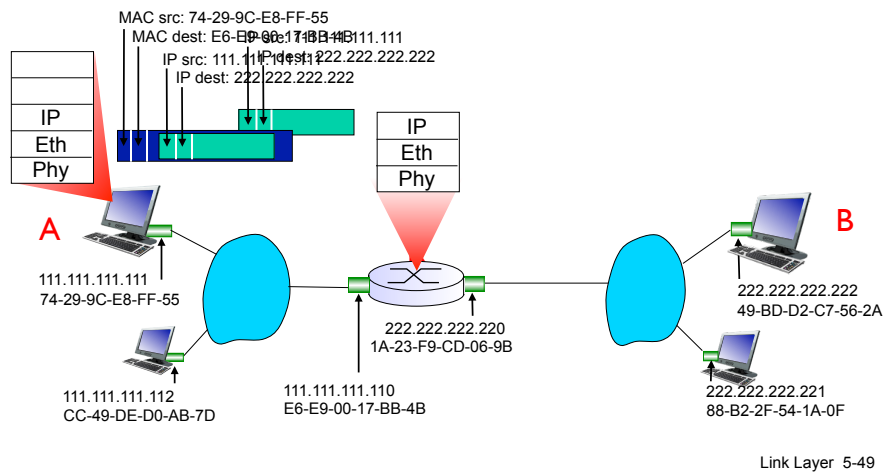

## Addressing: routing to another LAN

- ❖ R forwards datagram with IP source A, destination B
- ❖ R creates link-layer frame with B's MAC address as dest, frame contains A-to-B IP datagram

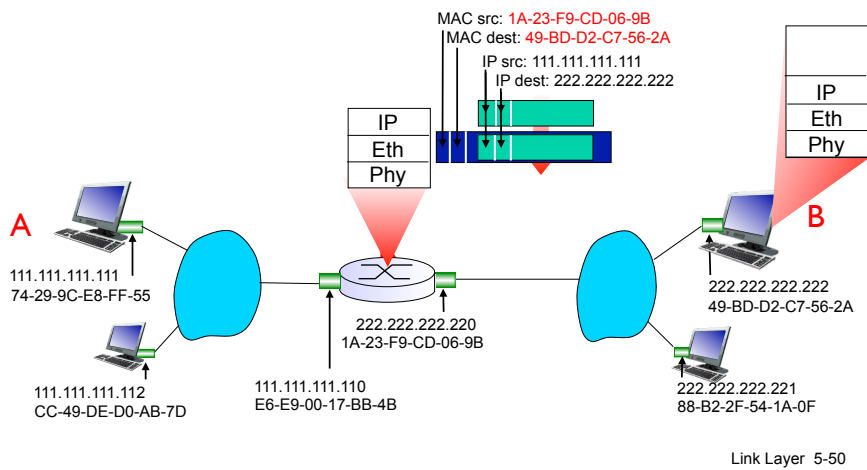

## Addressing: routing to another LAN

- ❖ R forwards datagram with IP source A, destination B
- ❖ R creates link-layer frame with B's MAC address as dest, frame contains A-to-B IP datagram

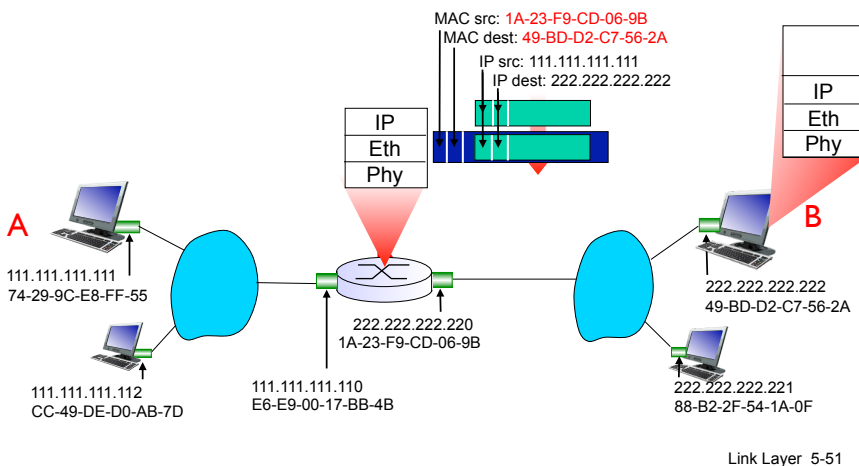

## Addressing: routing to another LAN

- ❖ R forwards datagram with IP source A, destination B
- ❖ R creates link-layer frame with B's MAC address as dest, frame contains A-to-B IP datagram

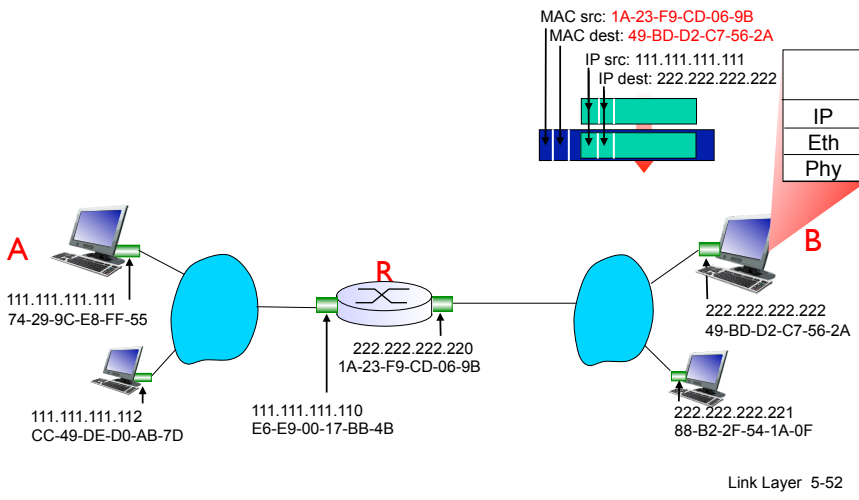

## Link layer, LANs: outline

- 5.1 introduction, services
- 5.2 error detection, correction
- 5.3 multiple access protocols
- 5.4 LANs
  - addressing, ARP
  - Ethernet
  - switches
  - VLANs
- 5.5 link virtualization: MPLS
- 5.6 data center networking
- 5.7 a day in the life of a web request

Link Layer 5-53

## Ethernet

“dominant” wired LAN technology:

- ❖ cheap \$20 for NIC
- ❖ first widely used LAN technology
- ❖ simpler, cheaper than token LANs and ATM
- ❖ kept up with speed race: 10 Mbps – 10 Gbps

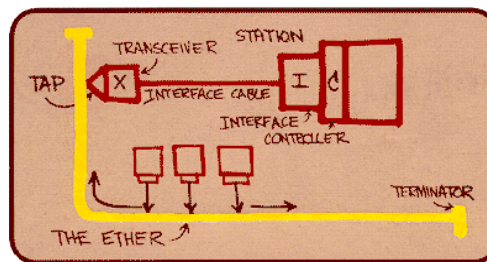

*Metcalfe's Ethernet sketch*

Link Layer 5-54

## Ethernet: physical topology

- ❖ **bus**: popular through mid 90s
  - all nodes in same collision domain (can collide with each other)
- ❖ **star**: prevails today
  - active **switch** in center
  - each “spoke” runs a (separate) Ethernet protocol (nodes do not collide with each other)

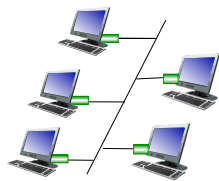

**bus**: coaxial cable

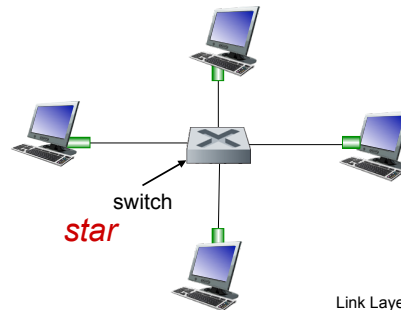

Link Layer 5-55

## Ethernet frame structure

sending adapter encapsulates IP datagram (or other network layer protocol packet) in **Ethernet frame**

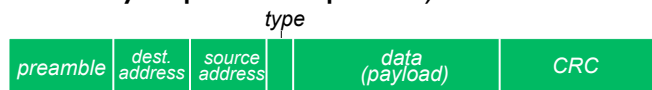

### **preamble:**

- ❖ 7 bytes with pattern 10101010 followed by one byte with pattern 10101011
- ❖ used to synchronize receiver, sender clock rates

Link Layer 5-56

## Ethernet frame structure (more)

- ❖ **addresses:** 6 byte source, destination MAC addresses
  - if adapter receives frame with matching destination address, or with broadcast address (e.g. ARP packet), it passes data in frame to network layer protocol
  - otherwise, adapter discards frame
- ❖ **type:** indicates higher layer protocol (mostly IP but others possible, e.g., Novell IPX, AppleTalk)
- ❖ **CRC:** cyclic redundancy check at receiver
  - error detected: frame is dropped



Link Layer 5-57

## Ethernet: unreliable, connectionless

- ❖ **connectionless:** no handshaking between sending and receiving NICs
- ❖ **unreliable:** receiving NIC doesn't send acks or nacks to sending NIC
  - data in dropped frames recovered only if initial sender uses higher layer rdt (e.g., TCP), otherwise dropped data lost
- ❖ Ethernet's MAC protocol: unslotted **CSMA/CD with binary backoff**

Link Layer 5-58

## 802.3 Ethernet standards: link & physical layers

- ❖ **many** different Ethernet standards
  - common MAC protocol and frame format
  - different speeds: 2 Mbps, 10 Mbps, 100 Mbps, 1 Gbps, 10G bps
  - different physical layer media: fiber, cable

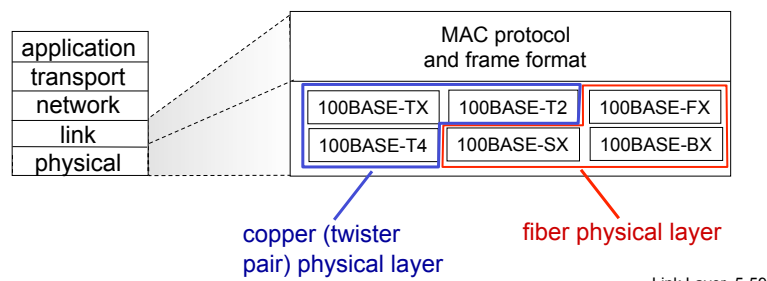

## Link layer, LANs: outline

- 5.1 introduction, services
- 5.2 error detection, correction
- 5.3 multiple access protocols
- 5.4 LANs
  - addressing, ARP
  - Ethernet
  - switches
  - VLANs
- 5.5 link virtualization: MPLS
- 5.6 data center networking
- 5.7 a day in the life of a web request

Link Layer 5-60

## Ethernet switch

- ❖ **link-layer device: takes an active role**
  - store, forward Ethernet frames
  - examine incoming frame's MAC address, **selectively** forward frame to one-or-more outgoing links when frame is to be forwarded on segment, uses CSMA/CD to access segment
- ❖ **transparent**
  - hosts are unaware of presence of switches
- ❖ **plug-and-play, self-learning**
  - switches do not need to be configured

Link Layer 5-61

## Switch: multiple simultaneous transmissions

- ❖ hosts have dedicated, direct connection to switch
- ❖ switches buffer packets
- ❖ Ethernet protocol used on each incoming link, but no collisions; full duplex
  - each link is its own collision domain
- ❖ **switching**: A-to-A' and B-to-B' can transmit simultaneously, without collisions

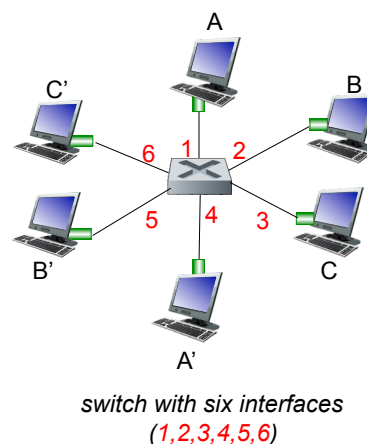

Link Layer 5-62

## Switch forwarding table

**Q:** how does switch know A' reachable via interface 4, B' reachable via interface 5?

❖ **A:** each switch has a **switch table**, each entry:

- (MAC address of host, interface to reach host, time stamp)
- looks like a routing table!

**Q:** how are entries created, maintained in switch table?

- something like a routing protocol?

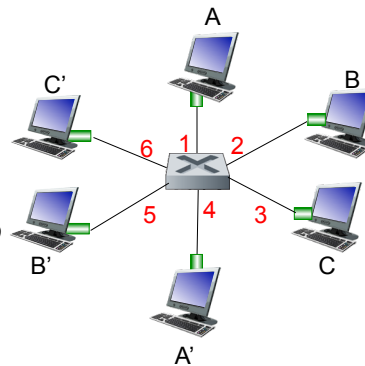

switch with six interfaces  
(1,2,3,4,5,6)

Link Layer 5-63

## Switch: self-learning

- ❖ switch **learns** which hosts can be reached through which interfaces
  - when frame received, switch “learns” location of sender: incoming LAN segment
  - records sender/location pair in switch table

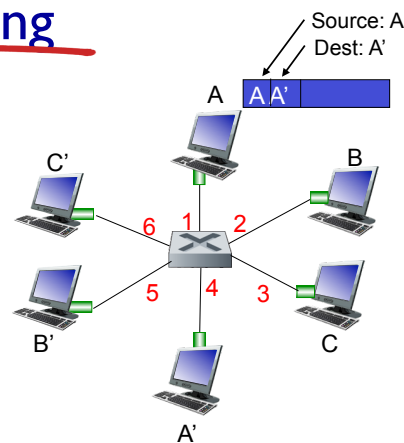

MAC addr	interface	TTL
A	1	60

Switch table  
(initially empty)

Link Layer 5-64

## Switch: frame filtering/forwarding

when frame received at switch:

1. record incoming link, MAC address of sending host
2. index switch table using MAC destination address
3. if entry found for destination
  - then {
    - if destination on segment from which frame arrived
      - then drop frame
      - else forward frame on interface indicated by entry
  - }
    - else flood /\* forward on all interfaces except arriving interface \*/

Link Layer 5-65

## Self-learning, forwarding: example

- ❖ frame destination, A', location unknown: *flood*
- ❖ destination A location known: *selectively send on just one link*

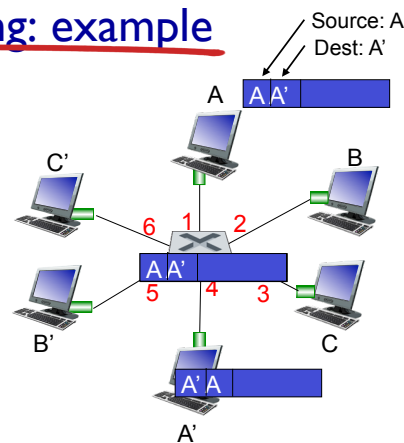

MAC addr	interface	TTL
A	1	60
A'	4	60

switch table  
(initially empty)

Link Layer 5-66

## Interconnecting switches

- ❖ switches can be connected together

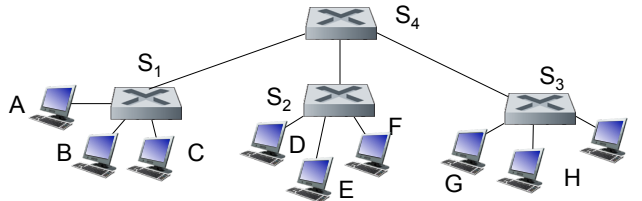

**Q:** sending from A to G - how does S<sub>1</sub> know to forward frame destined to F via S<sub>4</sub> and S<sub>3</sub>?

**A:** self learning! (works *exactly* the same as in single-switch case!)

Link Layer 5-67

## Self-learning multi-switch example

Suppose C sends frame to I, I responds to C

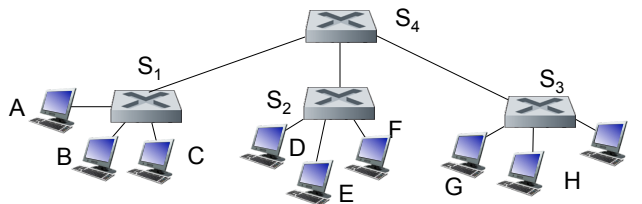

- ❖ **Q:** show switch tables and packet forwarding in S<sub>1</sub>, S<sub>2</sub>, S<sub>3</sub>, S<sub>4</sub>

Link Layer 5-68

# Institutional network

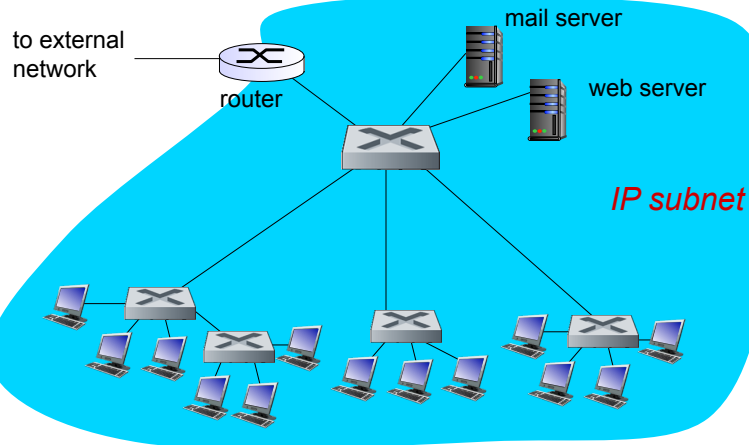

Link Layer 5-69

## Switches vs. routers

both are store-and-forward:

- **routers:** network-layer devices (examine network-layer headers)
- **switches:** link-layer devices (examine link-layer headers)

both have forwarding tables:

- **routers:** compute tables using routing algorithms, IP addresses
- **switches:** learn forwarding table using flooding, learning, MAC addresses

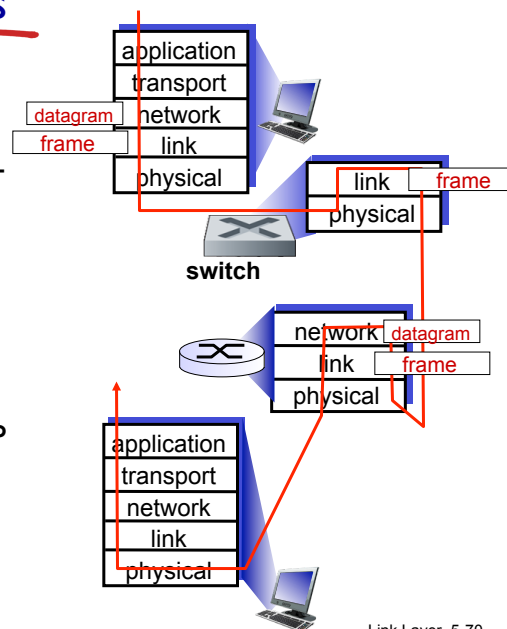

Link Layer 5-70

# VLANs: motivation

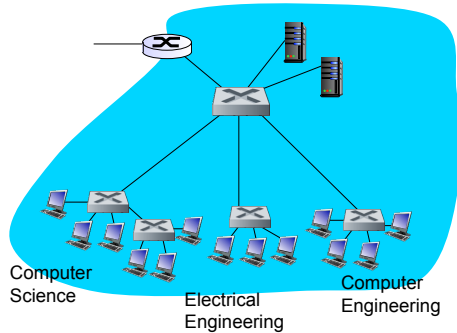

consider:

- ❖ CS user moves office to EE, but wants connect to CS switch?
- ❖ single broadcast domain:
  - all layer-2 broadcast traffic (ARP, DHCP, unknown location of destination MAC address) must cross entire LAN
  - security/privacy, efficiency issues

Link Layer 5-71

# VLANs

## **Virtual Local Area Network**

switch(es) supporting VLAN capabilities can be configured to define multiple **virtual** LANs over single physical LAN infrastructure.

**port-based VLAN:** switch ports grouped (by switch management software) so that **single** physical switch .....

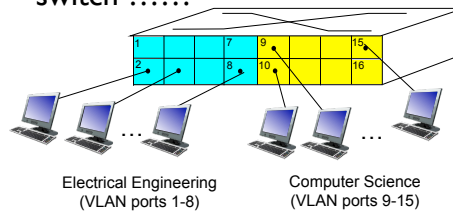

... operates as **multiple** virtual switches

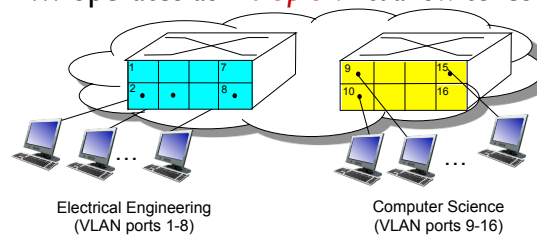

Link Layer 5-72

## Port-based VLAN

- ❖ **traffic isolation:** frames to/from ports 1-8 can *only* reach ports 1-8
  - can also define VLAN based on MAC addresses of endpoints, rather than switch port
- ❖ **dynamic membership:** ports can be dynamically assigned among VLANs
- ❖ **forwarding between VLANs:** done via routing (just as with separate switches)
  - in practice vendors sell combined switches plus routers

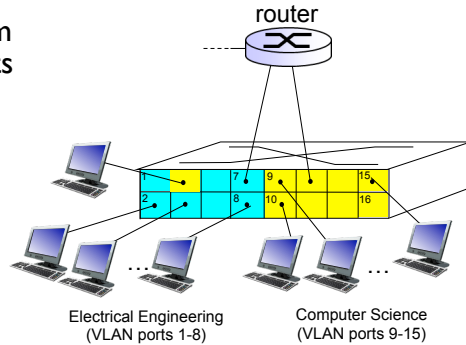

Link Layer 5-73

## VLANs spanning multiple switches

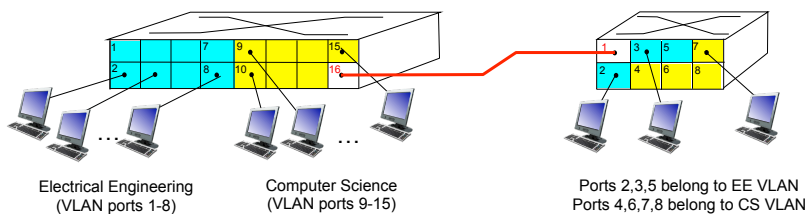

- ❖ **trunk port:** carries frames between VLANs defined over multiple physical switches
  - frames forwarded within VLAN between switches can't be vanilla 802.1 frames (must carry VLAN ID info)
  - 802.1q protocol adds/removed additional header fields for frames forwarded between trunk ports

Link Layer 5-74

## 802.1Q VLAN frame format

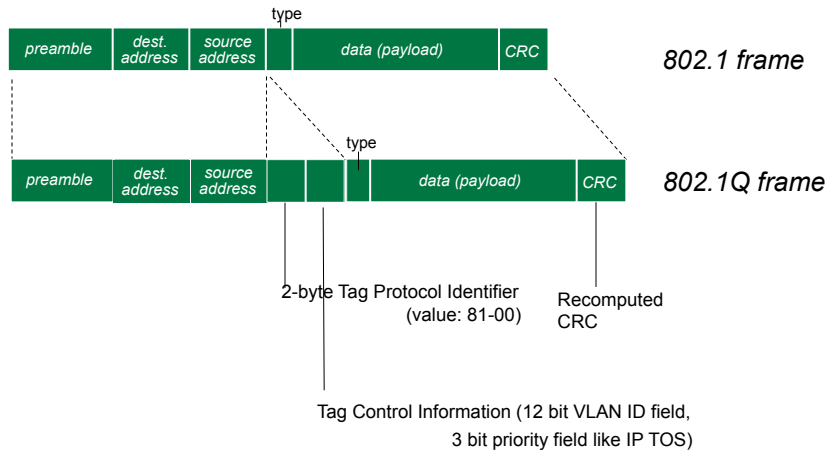

Link Layer 5-75

## Link layer, LANs: outline

- 5.1 introduction, services
- 5.2 error detection, correction
- 5.3 multiple access protocols
- 5.4 LANs
  - addressing, ARP
  - Ethernet
  - switches
  - VLANS
- 5.5 link virtualization: MPLS
- 5.6 data center networking
- 5.7 a day in the life of a web request

Link Layer 5-76

## Multiprotocol label switching (MPLS)

- ❖ initial goal: high-speed IP forwarding using fixed length label (instead of IP address)
  - fast lookup using fixed length identifier (rather than shortest prefix matching)
  - borrowing ideas from Virtual Circuit (VC) approach
  - but IP datagram still keeps IP address!

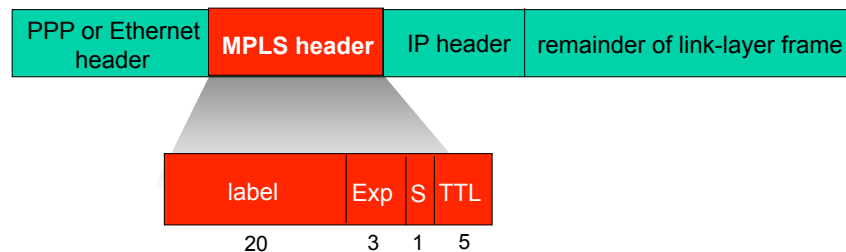

Link Layer 5-77

## MPLS capable routers

- ❖ a.k.a. label-switched router
- ❖ forward packets to outgoing interface based only on label value (*don't inspect IP address*)
  - MPLS forwarding table distinct from IP forwarding tables
- ❖ **flexibility:** MPLS forwarding decisions can *differ* from those of IP
  - use destination *and* source addresses to route flows to same destination differently (traffic engineering)
  - re-route flows quickly if link fails: pre-computed backup paths (useful for VoIP)

Link Layer 5-78

## MPLS versus IP paths

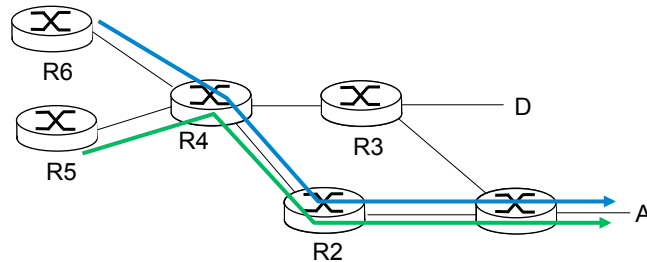



- ❖ **IP routing:** path to destination determined by destination address alone  IP router

Link Layer 5-79

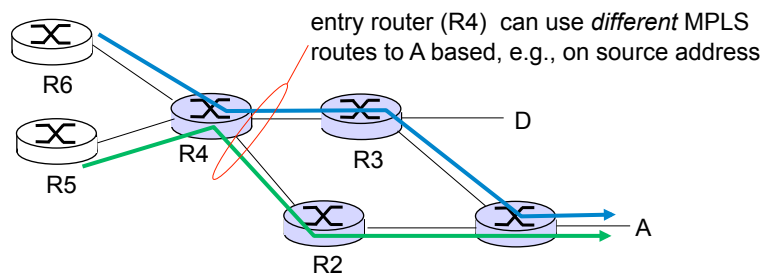
## MPLS versus IP paths



- ❖ **IP routing:** path to destination determined by destination address alone  IP-only router
- ❖ **MPLS routing:** path to destination can be based on source *and* dest. address  MPLS and IP router
  - **fast reroute:** precompute backup routes in case of link failure

Link Layer 5-80

## MPLS signaling

- ❖ modify OSPF, IS-IS link-state flooding protocols to carry info used by MPLS routing,
  - e.g., link bandwidth, amount of “reserved” link bandwidth
- ❖ entry MPLS router uses *RSVP-TE signaling protocol* to set up MPLS forwarding at downstream routers

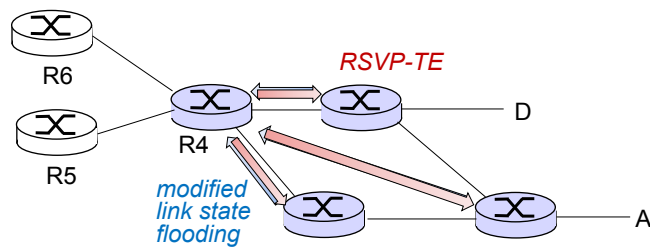

Link Layer 5-81

## MPLS forwarding tables

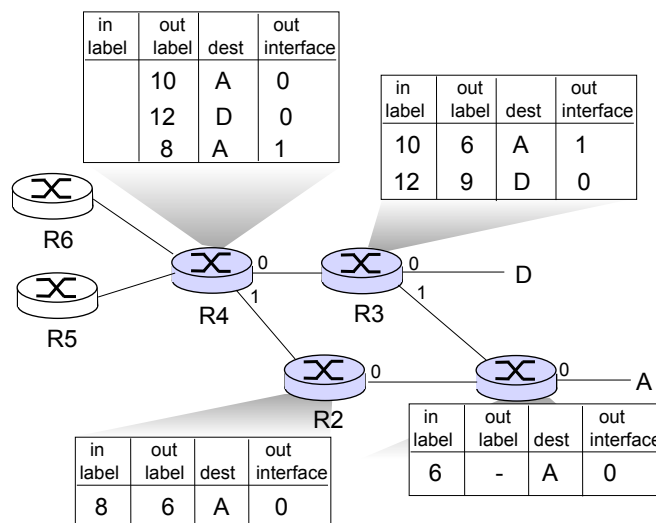

Link Layer 5-82

## Link layer, LANs: outline

- 5.1 introduction, services
- 5.2 error detection, correction
- 5.3 multiple access protocols
- 5.4 LANs
  - addressing, ARP
  - Ethernet
  - switches
  - VLANs
- 5.5 link virtualization: MPLS
- 5.6 data center networking
- 5.7 a day in the life of a web request

Link Layer 5-83

## Data center networks

- ❖ 10's to 100's of thousands of hosts, often closely coupled, in close proximity:
  - e-business (e.g. Amazon)
  - content-servers (e.g., YouTube, Akamai, Apple, Microsoft)
  - search engines, data mining (e.g., Google)
- ❖ challenges:
  - multiple applications, each serving massive numbers of clients
  - managing/balancing load, avoiding processing, networking, data bottlenecks

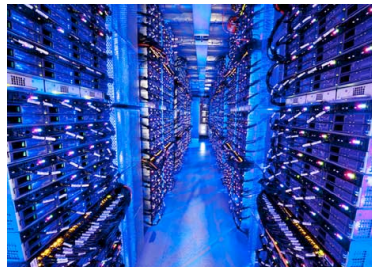

Inside a 40-ft Microsoft container,  
Chicago data center

Link Layer 5-84

# Data center networks

## load balancer: application-layer routing

- receives external client requests
- directs workload within data center
- returns results to external client (hiding data center internals from client)

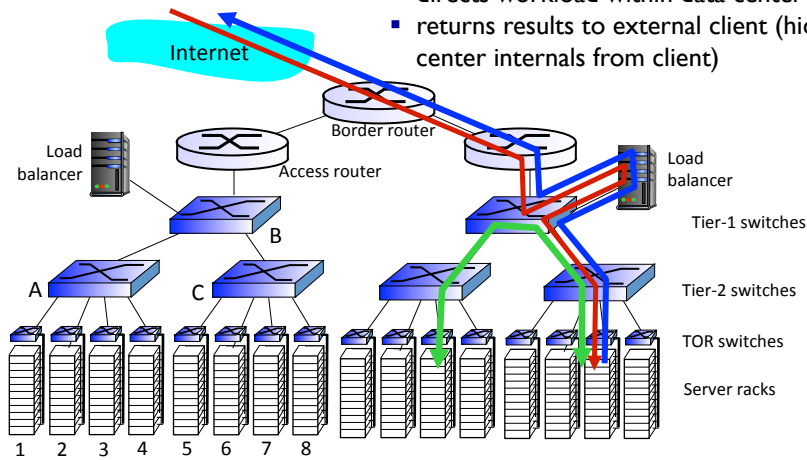

Link Layer 5-85

# Data center networks

- ❖ rich interconnection among switches, racks:
  - increased throughput between racks (multiple routing paths possible)
  - increased reliability via redundancy

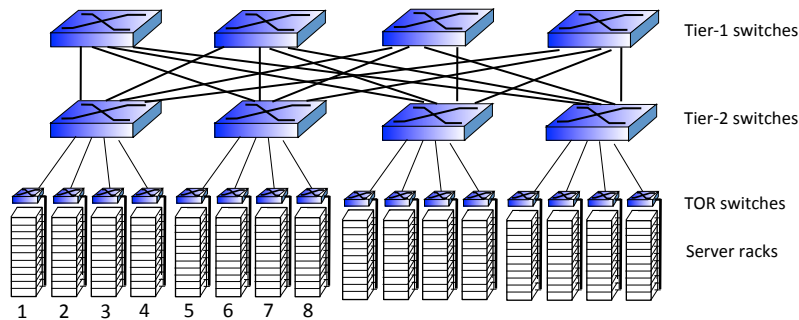

## Link layer, LANs: outline

- 5.1 introduction, services
- 5.2 error detection, correction
- 5.3 multiple access protocols
- 5.4 LANs
  - addressing, ARP
  - Ethernet
  - switches
  - VLANs
- 5.5 link virtualization: MPLS
- 5.6 data center networking
- 5.7 a day in the life of a web request

Link Layer 5-87

## Synthesis: a day in the life of a web request

- ❖ journey down protocol stack complete!
  - application, transport, network, link
- ❖ putting-it-all-together: synthesis!
  - *goal*: identify, review, understand protocols (at all layers) involved in seemingly simple scenario: requesting www page
  - *scenario*: student attaches laptop to campus network, requests/receives www.google.com

Link Layer 5-88

## A day in the life: scenario

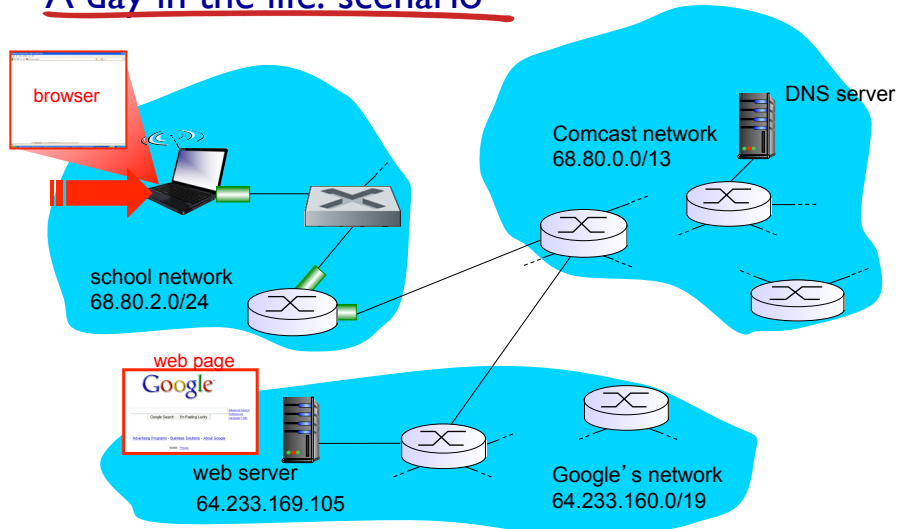

Link Layer 5-89

## A day in the life... connecting to the Internet

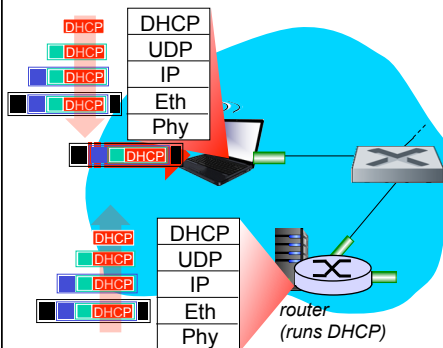

- ❖ connecting laptop needs to get its own IP address, addr of first-hop router, addr of DNS server: use *DHCP*
- ❖ DHCP request *encapsulated* in *UDP*, encapsulated in *IP*, encapsulated in *802.3* Ethernet
- ❖ Ethernet frame *broadcast* (dest: FFFFFFFF) on LAN, received at router running *DHCP* server
- ❖ Ethernet *demuxed* to IP demuxed, UDP demuxed to DHCP

Link Layer 5-90

## A day in the life... connecting to the Internet

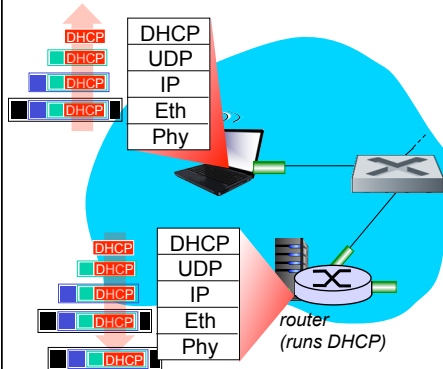

- ❖ DHCP server formulates **DHCP ACK** containing client's IP address, IP address of first-hop router for client, name & IP address of DNS server
- ❖ encapsulation at DHCP server, frame forwarded (*switch learning*) through LAN, demultiplexing at client
- ❖ DHCP client receives DHCP ACK reply

Client now has IP address, knows name & addr of DNS server, IP address of its first-hop router

Link Layer 5-91

## A day in the life... ARP (before DNS, before HTTP)

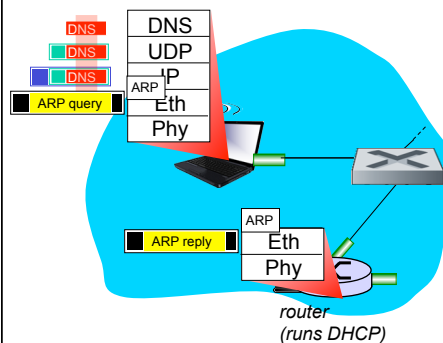

- ❖ before sending **HTTP** request, need IP address of **www.google.com**: **DNS**
- ❖ DNS query created, encapsulated in UDP, encapsulated in IP, encapsulated in Eth. To send frame to router, need MAC address of router interface: **ARP**
- ❖ **ARP query** broadcast, received by router, which replies with **ARP reply** giving MAC address of router interface
- ❖ client now knows MAC address of first hop router, so can now send frame containing DNS query

Link Layer 5-92

## A day in the life... using DNS

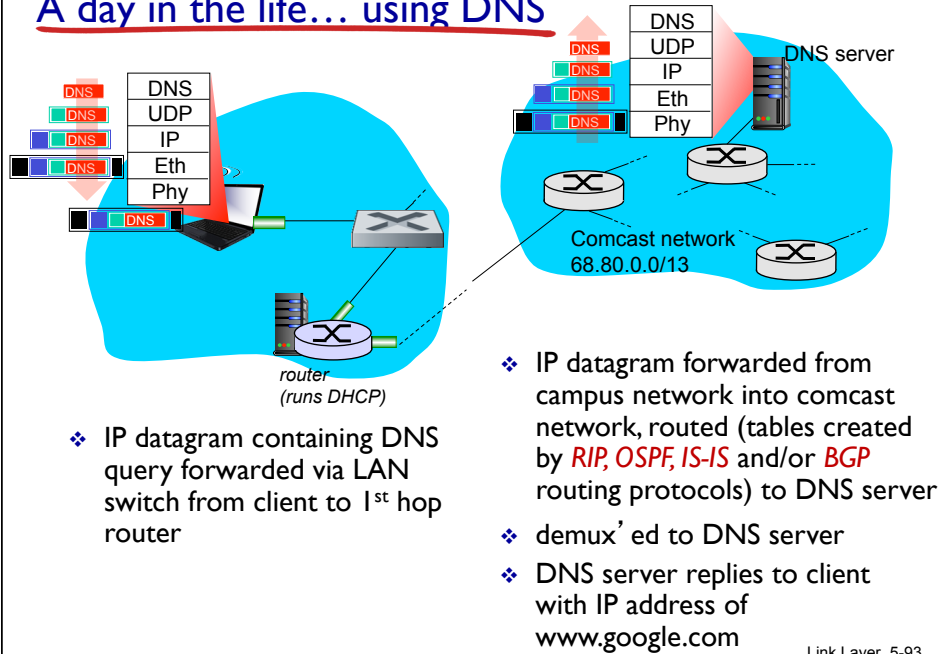

## A day in the life... TCP connection carrying HTTP

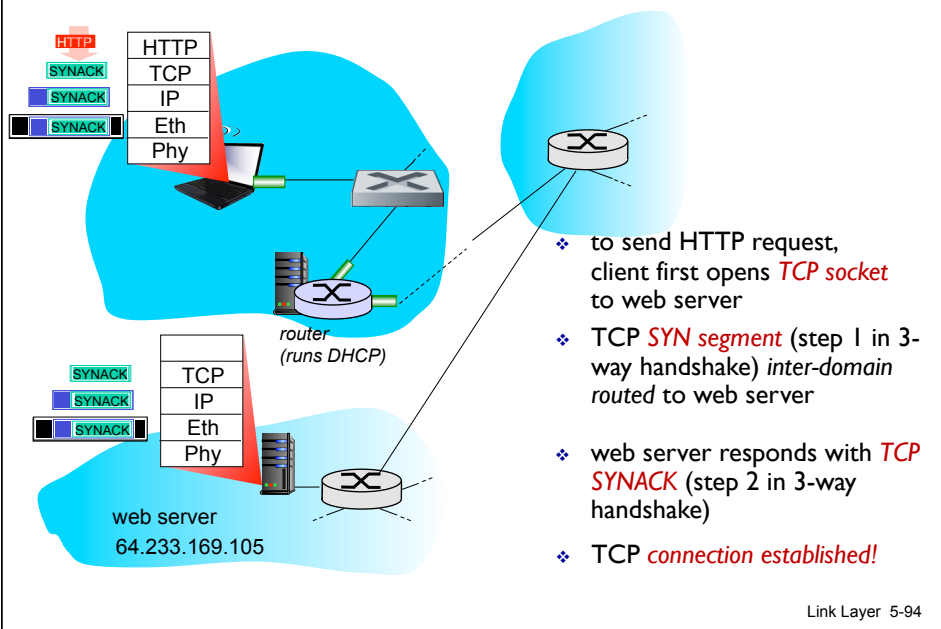

## A day in the life... HTTP request/reply

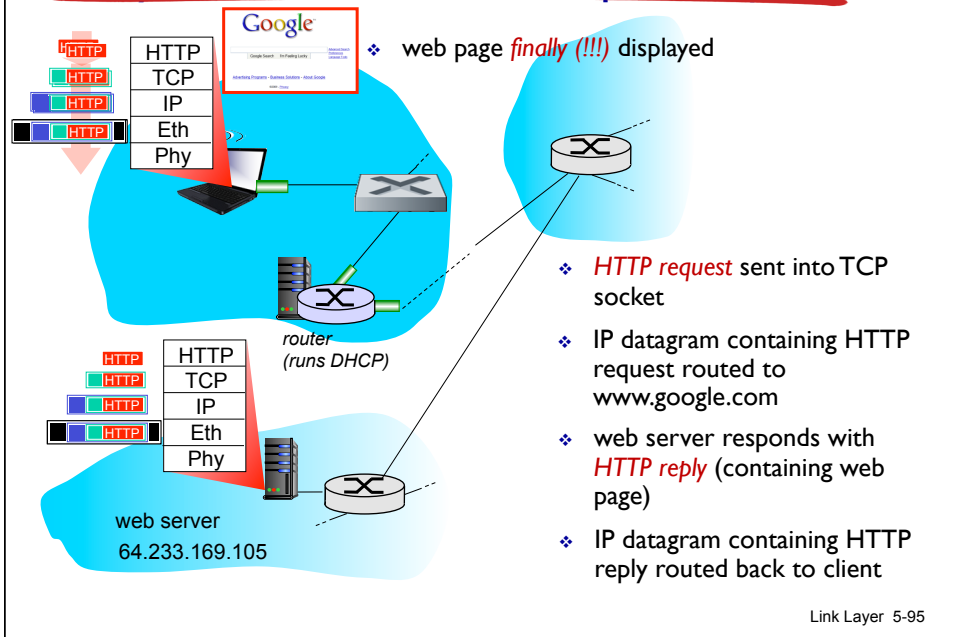

## Chapter 5: Summary

- ❖ principles behind data link layer services:
  - error detection, correction
  - sharing a broadcast channel: multiple access
  - link layer addressing
- ❖ instantiation and implementation of various link layer technologies
  - Ethernet
  - switched LANS, VLANs
  - virtualized networks as a link layer: MPLS
- ❖ synthesis: a day in the life of a web request

## Chapter 5: let's take a breath

- ❖ journey down protocol stack *complete* (except PHY)
- ❖ solid understanding of networking principles, practice
- ❖ ..... could stop here .... but *lots* of interesting topics!
  - wireless
  - multimedia
  - security
  - network management

Link Layer 5-97