

CS 2742 (Logic in Computer Science)

Lecture 9

Antonina Kolokolova

September 28, 2009

3.1 Formulas and circuits

It is often useful to draw a formula (or an arithmetic expression) as a diagram to show the order of evaluation of its parts. For example, the following diagram shows how to evaluate $3 + 5 * 7$:

Example 1.

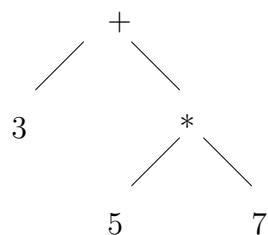

Essentially this diagram tells us in which order to evaluate parts of the original arithmetic expression. Here, first we (recursively) have to evaluate the expressions on both sides of the $+$, and then apply the arithmetic operation $+$ to the two results.

Similarly, we can have a diagram that shows the order of evaluation of a propositional formula (just change numbers to propositional variables and $+$, $*$ to \vee , \wedge , \neg .)

We call this representation a *tree* or *parse tree* of an arithmetic expression. To construct a parse tree of a formula of the form $A \circ B$, where A and B are formulas themselves and \circ is \wedge , \vee , \rightarrow or \leftrightarrow , put the symbol for \circ on top, and the trees for A and B under it; connect \circ to the top symbols of trees for A and B . If the connective is \neg , put only one line to the tree for the expression being negated. When run out of connectives, put variables. To evaluate a formula like this, start by evaluating, for every connective, its subformulas and then applying the connective to the result

Example 2. Consider a propositional formula $(p \vee q) \wedge \neg r) \wedge (\neg p \vee ((p \vee q) \wedge \neg r))$. On inputs $(0, 1, 1)$ (that is, $p = 0, q = 1, r = 1$) this formula evaluates to 0: $(p \vee q)$ is 1, $((p \vee q) \wedge \neg r)$ is 0, the same expression in the second part is also 0, and $\neg p \vee \dots$ is 1, but because the left side of the \wedge was 0 the whole formula evaluates to 0.

Note that in this formula there is a redundancy: there are two identical subformulas (subtrees) computing $(p \vee q) \wedge \neg r$. We can combine them to obtain a *circuit*. A circuit has an

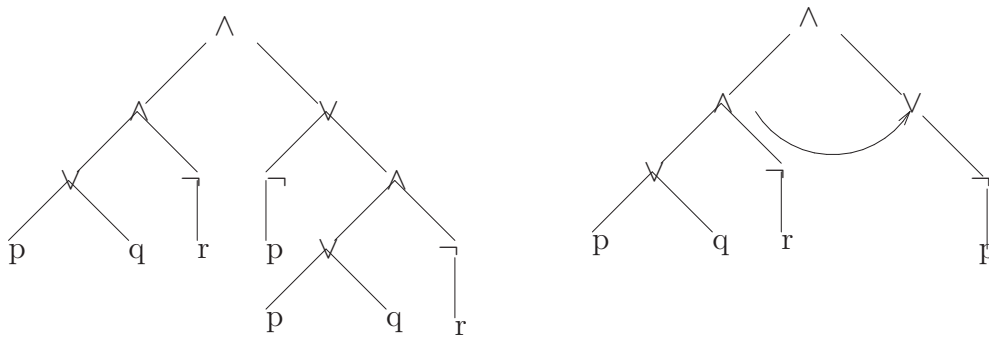

Figure 1: $(p \vee q) \wedge \neg r) \wedge (\neg p \vee ((p \vee q) \wedge \neg r))$. The first is the parse tree for the formula and the second is a corresponding circuit.

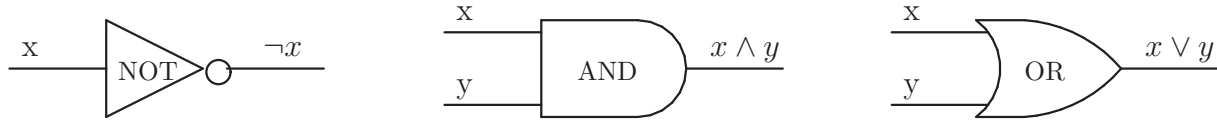

Figure 2: Types of gates in a digital circuit.

additional property that computed values of subformulas can be reused without recomputation. This often makes circuits much more concise than formulas.

With this we arrive to the notion of circuits corresponding to the circuits in computer hardware. A hardware circuit consists of elements (called gates) performing exactly the operations of conjunction, disjunction and negation. The following figure shows the notation used in digital circuits and computer architecture literature to draw circuits.

A node in the tree or circuit diagram is usually called the *gate*. In a Boolean circuit, there are \vee, \wedge, \neg gates, and also *input* gates and one *output* gate. The figure 3.1 shows a circuit for the formula from example 2 written as a digital circuit.

Example 3.

Recall the Boolean function *Majority* (x, y, z) which evaluates to 1 if and only if at least two of its inputs are 1. It can be represented by the formula $(x \wedge y) \vee (y \wedge z) \vee (x \wedge z)$. The following circuit computes majority of its three inputs.

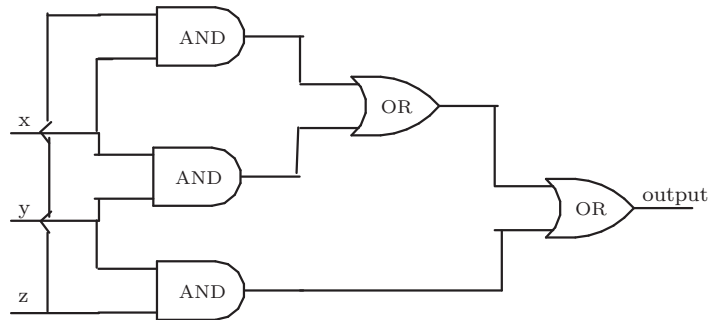

So how do we construct a circuit for a given function? The most natural way (although not giving the best circuit in many cases) is to start with a truth table of a function, write a

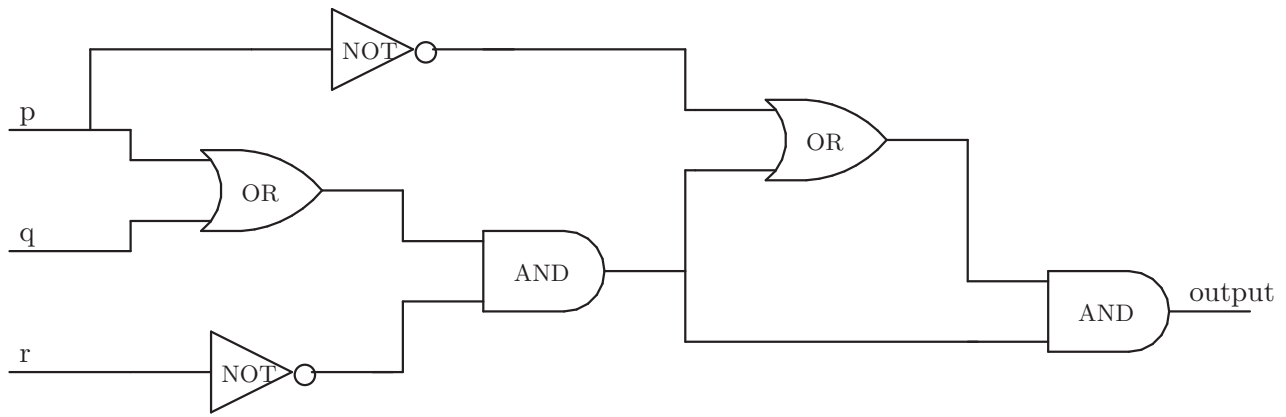

Figure 3: A digital circuit for the formula from example 2.

CNF or a DNF formula for it, then simplify it to make it smaller, and finally encode it as a circuit. Can we do better than that? Sometimes, yes, but in general we do not have an algorithm that, given a truth table, constructs us the best possible circuit (well, short of a very brute-force method of trying all possible circuits up to the size of the truth table to see if any of them work). This is an open problem in computer science, to design such an algorithm. However, we know that for most Boolean functions the best circuit is of the size comparable with the size of its truth table (think about a “random-looking” column in a truth table: how would you describe it other than writing it out?).

3.2 Doing arithmetic with Boolean circuits

Binary notation: every natural number can be written using only 0s and 1s. There is a convention for defining negative numbers, rational numbers, reals and so on (for example, real numbers are infinite strings of 0s and 1s). Just as a number 209 in decimal notation is $2 \cdot 10^2 + 0 \cdot 10^1 + 9 \cdot 10^0$, in binary notation it is 11010001.

How to convert from decimal into binary? If the number is even, put a 0, if it is odd, put a 1, then divide by 2 (rounding down) and repeat until got to 1. Digits of a number in binary are called bits.

What does it have to do with Boolean circuits? Boolean circuits can compute bits of numbers.

Example 4. Think of adding numbers $3_{10} = 11_2$ and $5_{10} = 101_2$ (here, the subscript denotes which base we are using, 10 or 2).

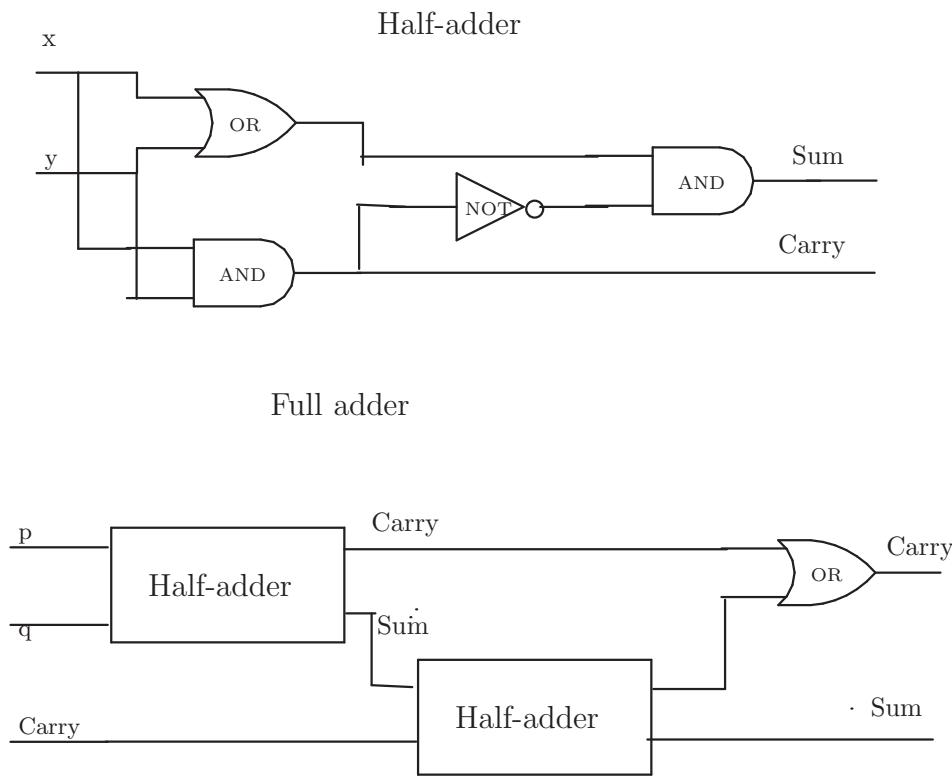

Figure 4: A half-adder and a full adder used to add numbers in binary

11
011
101
—
1000

Here, the top row keeps track of the carry as we are adding bits from right to left. This tells us that to compute a bit in the middle we need three inputs: the two corresponding bits of the numbers and a carry from the previous step. This also tells us that here we need two outputs of the circuits (in terms of Boolean functions, we can think about each output as computed separately; however, in real life we reuse parts of circuits to produce several outputs).

A construction of a circuit for addition consists of three parts. First, we construct a *half-adder* which adds two bits without considering the carry and outputs a sum and a carry from that addition. Such a circuit could be used to add two one-bit numbers and is used to add the two lowest bits of the numbers. Then we will use a half-adder to construct a circuit *full adder* which adds two bits taking into account the carry. And then a number of such full adders are connected recursively (that is, with an output of one feeding as an input do the next) to compute the sum of an n -bit number. See figure 4 for the circuit diagrams.

In the same fashion any arithmetic function can be evaluated using Boolean circuits to evaluate bits of the resulting number.